

MANUAL

MODEL SX14 NMEA 0183 Expander

DESCRIPTION: The SX14 Expander is an advanced version of its predecessor (XP15) with very low power consumption, hi-speed operation to 38,400 baud, and outputs that withstand indefinite short circuits. It provides a single opto-isolated input and four independent differential (RS-422) outputs which are also compatible with RS-232 listeners.

Many marine instruments, although compliant with the NMEA 0183 specification, do not provide sufficient drive capability for multiple listeners. To overcome this, the SX14 has four outputs, each of which can drive multiple listeners, both RS-422 and/or RS-232, as needed. All outputs are isolated from each other, so that shorting one will not affect the others. A green data LED and a yellow fault LED indicate the unit is operating and connected properly.

The SX14 can operate on any DC voltage from 8-30 Vdc. A green LED on the unit flashes when input data is detected, while a yellow (overcurrent) LED flashes if a supply current overload occurs. Current overload usually occurs because an output terminal is misconnected.

TYPICAL INSTALLATION: The SX14 accepts one NMEA talker input, such as a GPS. The input signal is split into 4 outputs, each able to drive either a differential, RS-422 or Opto-isolated Listener, or a single-ended Listener such as RS-232. Example connections are shown in Figure 1.

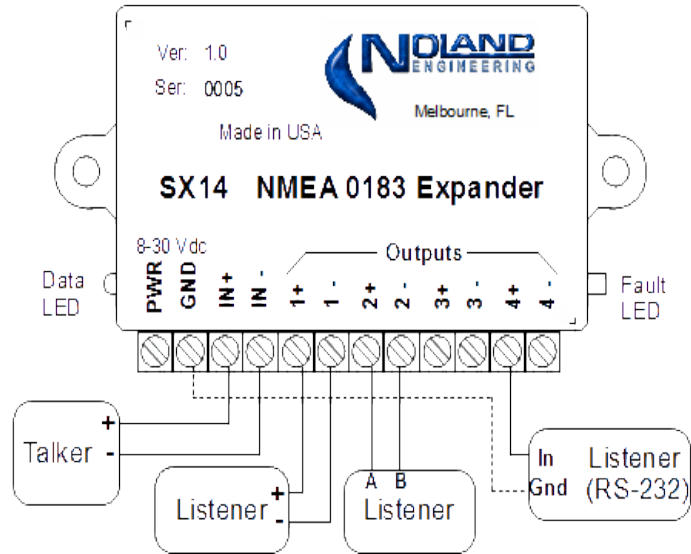

In the example, outputs 1 and 2 are connected to differential listeners that have “+/-” (or “A/B”) inputs which may also be labeled “A/B” or “RXA/RXB”. A third Listener (RS-232) uses only a “+” output from the SX14 to connect to the single input terminal “In”. The dashed “Gnd” wire may be needed in some installations for stable data, but is often not required.

In the case of an RS-232 or other single-ended Talker, the connection should be made as shown in Figure 2. The “Out” connection from the Talker must go to “IN+” on the SX14 while “IN-” connects to the Talker “Gnd” terminal.

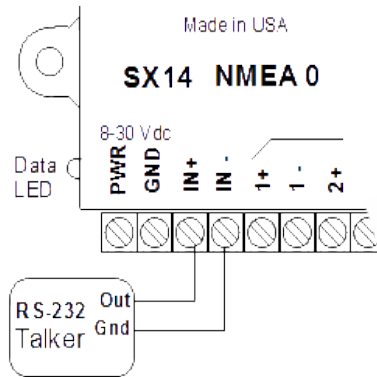

LED Operation: Two LED's are provided to verify proper operation and connection of the SX14. The green data LED flashes whenever input data is detected. When there is no data, the SX14 automatically switches into a low power “Standby” state, where it remains until data is again detected.

The yellow LED indicates an overcurrent condition, which is most often caused by shorting or misconnecting an output. If the yellow LED flashes in sync with the green LED, then one of the “-” output terminals is shorted. This usually happens if a “-” output terminal is connected to an RS-232 “Gnd”. Making the proper connection (see Figure 1) will clear the fault.

Additional Listeners: The SX14 is robust enough to drive more than 4 Listeners. You can double up Listeners to any of the outputs, but if you try connecting too many, the yellow LED will flash in sync with the green data LED. This warns you that the current limit of the SX14 has been reached.

You can also connect single-ended and differential Listeners to the same output as shown in Figure 3. In this example, output “4+” and “4-” are connected to a differential Listener, while “4+” is also driving a single-ended Listener. It is generally better to double-up a differential and a single-ended Listener to the same output, since single-ended listeners draw very little current compared to differential ones. Doubling up two differential Listeners on one output does cause a small signal drop on that output, but most NMEA Listeners can tolerate it.

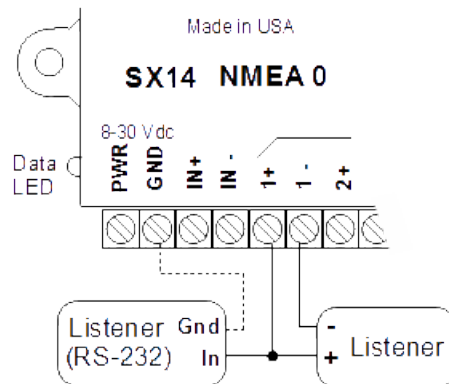

Specifications

| | |
|------------------------------|----------------------------------|
| Supply Voltage | 8-30 Vdc |
| Supply Current (operating) | 75 ma. typ. (all outputs loaded) |
| Standby Current (no data) | <4 ma. typ. |
| Input Impedance (IN+ to IN-) | >500 ohm |
| Output Level | 4V typ. into 500 ohms |
| Data Rate | 38,400 baud max. |
| Overload Indicator | >80ma |
| Operating Temp (degC) | 0 – 50 |
| Humidity range | 0 – 100% (non-condensing) |
| Size, Weight | 3.5 x 2.0 x 0.9 in., 2 oz. |

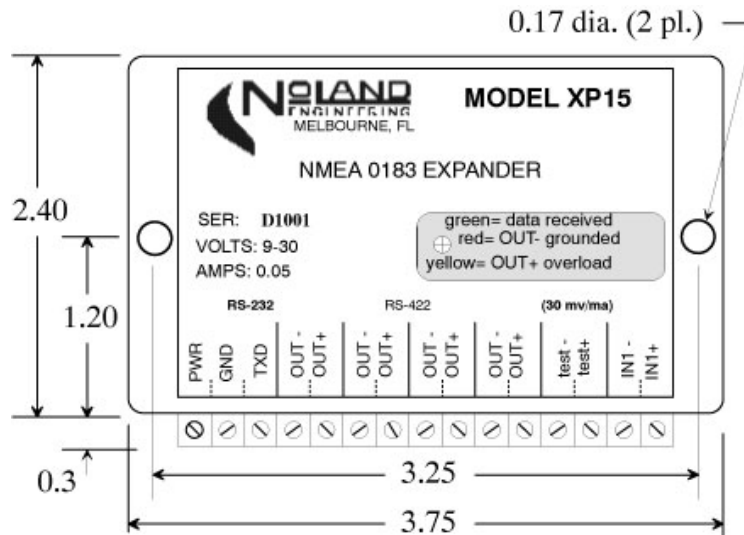

NoLand Engineering Inc
728 E Lincoln Ave
Suite 3
Melbourne, FL 32901

Tel: (321) 951 –7329 Fax: (321) 951-8773
<http://www.nolandeng.com>
 email: info@nolandeng.com